

4 SECTION
S3.10 1' = 1'-0"

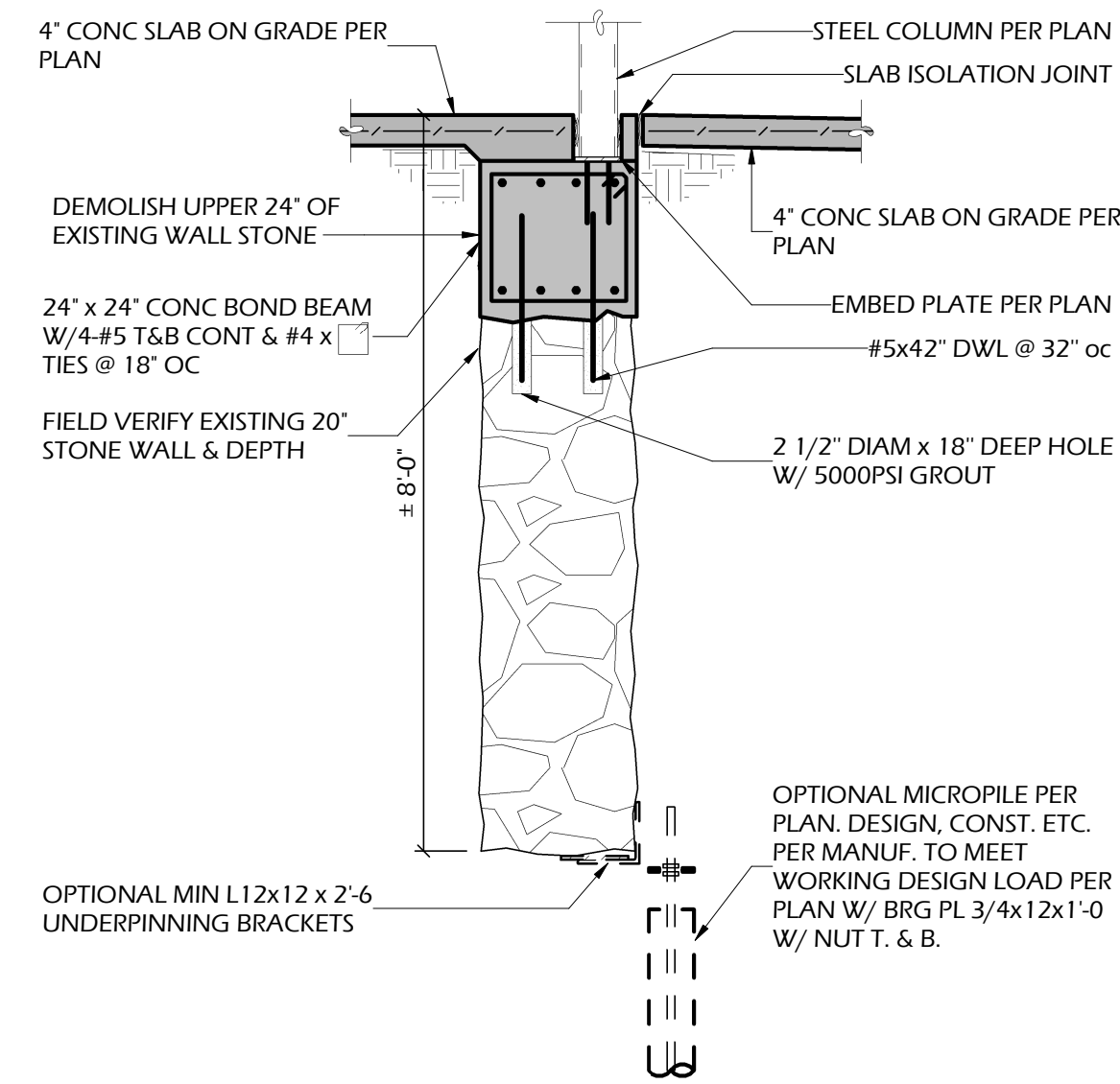

3 SECTION
S3.10 1/2' = 1'-0"

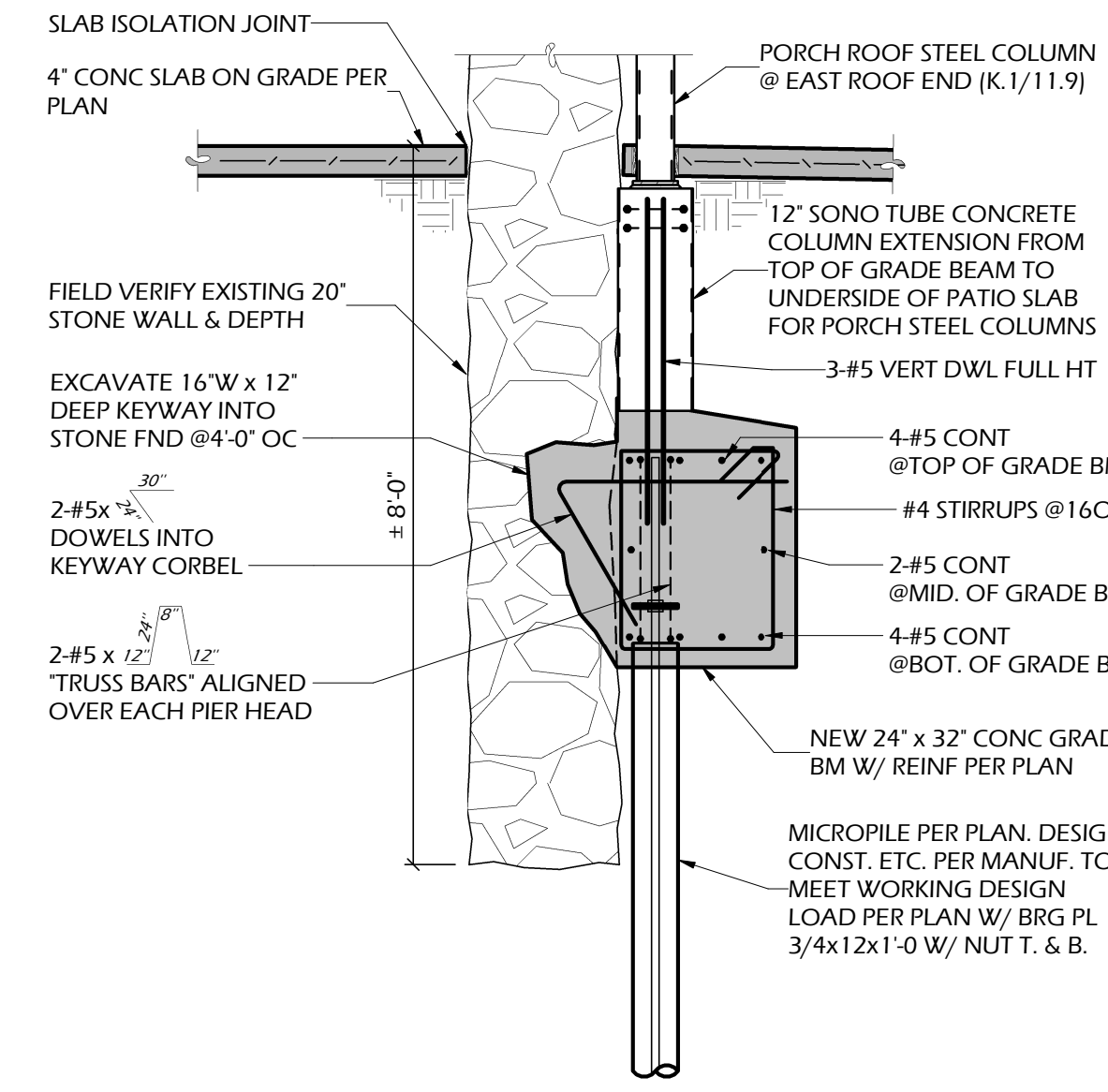

2 SECTION
S3.10 1/2' = 1'-0"

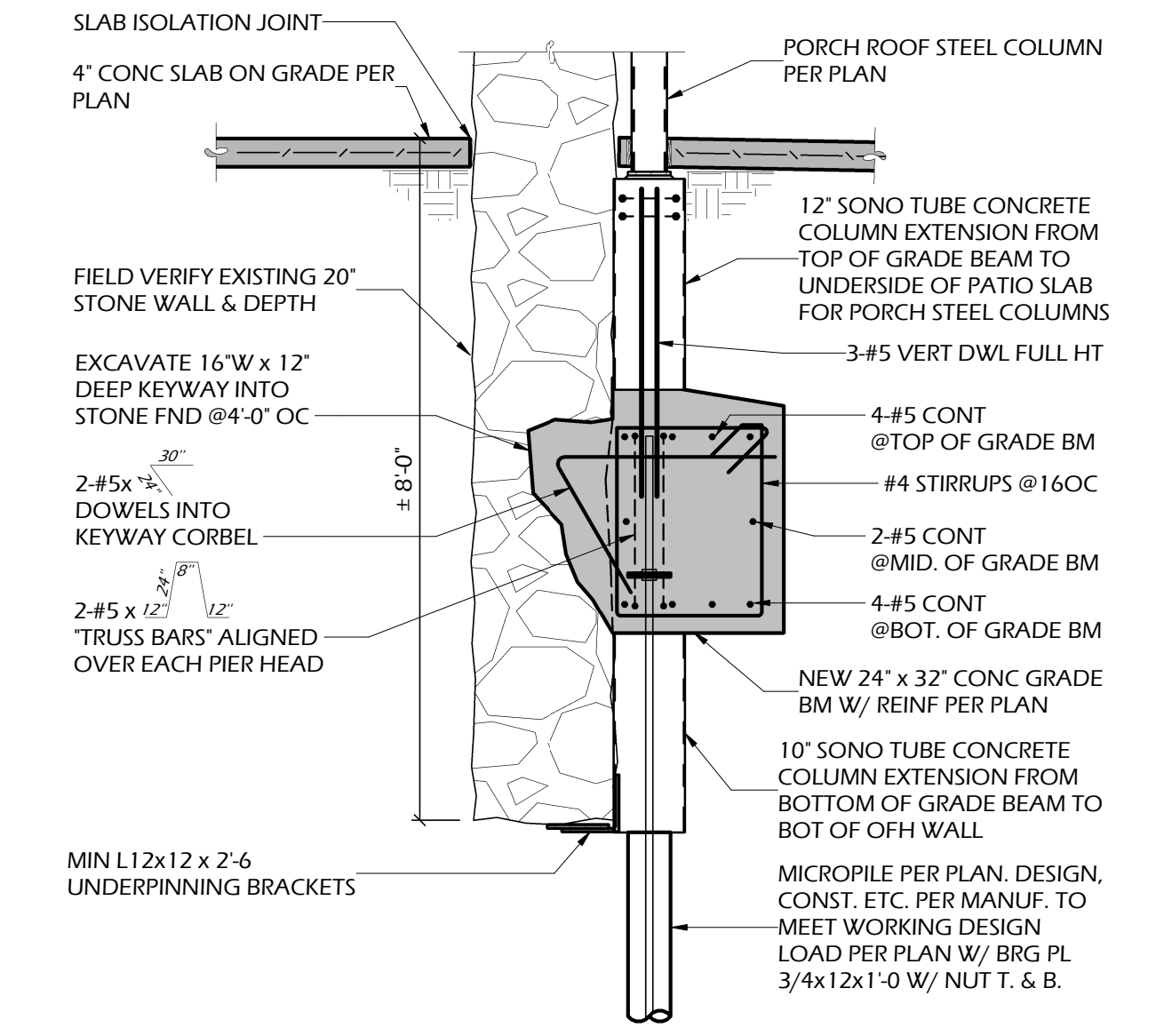

1 SECTION
S3.10 1/2' = 1'-0"

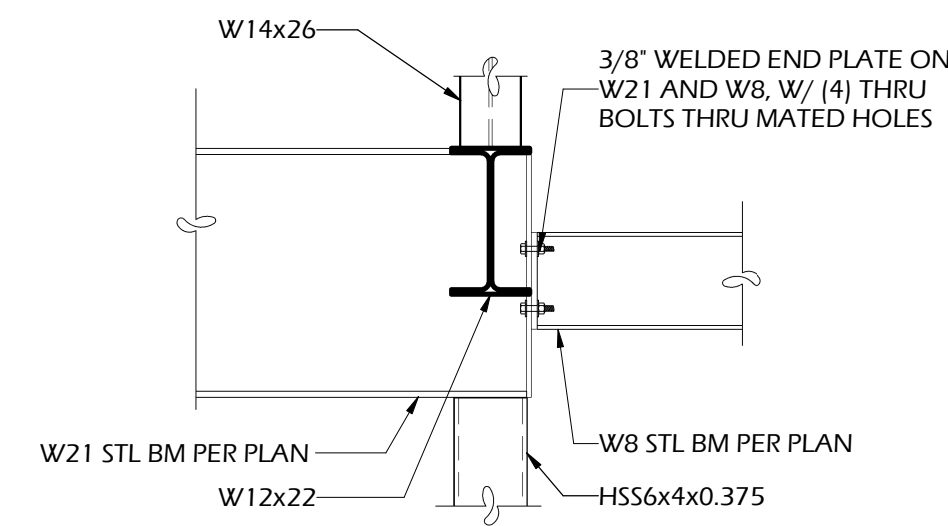

6 SECTION
S3.10 3/4' = 1'-0"

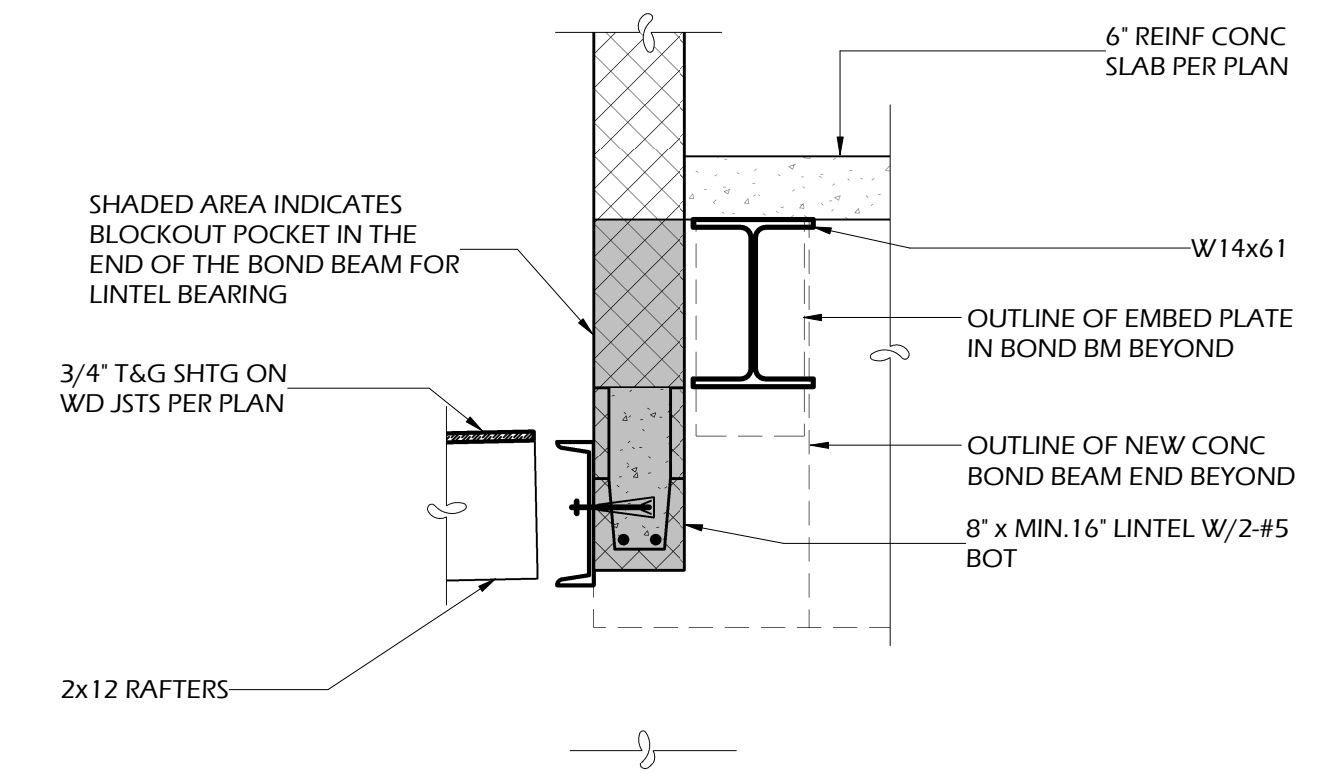

5 SECTION
S3.10 3/4' = 1'-0"

PROJECT No:
ISSUE DATE: 12/17/21
REVISIONS:
2 ASI.02 07/29/2022
3 Delta 3 08/31/2022

SHEET TITLE:
TYPICAL DETAILS

SHEET NUMBER:

S3.10